



INSTRUCTION MANUAL

R-LH8080 WALL HUNG BASIN



CONTENT

Safety Precautions	1
Important Safety Information	2
Packing List	3
Product Dimensions	4
Recommended Installation Detail	5
Installation Instructions	6
Warranty	7
Customer Services	8

CUSTOMER SERVICES

AFTER SALES SERVICE

Our Customer Support Team is comprehensively trained to provide help and advice, spare parts or a service visit.

SPARE PARTS

We maintain an extensive stock of spares and aim to have functional parts available for ten years from the date of final manufacture of the product. Spares can be purchased from approved stockists or merchants (locations on request) or direct from Customer Services Department. Spares direct will normally be dispatched within two working days.

NOTE

In the interest of safety, spares requiring exposure to mains voltages can only be sent to qualified persons.

SERVICE

Our Customer Support Team is available to provide a quality service at a reasonable cost. You will be assured of the services of a trained engineer / agent, genuine spares and a 6-month guarantee on the repair.

CONTACT US

RIGEL TECHNOLOGY (S) PTE LTD

No. 12 Kaki Bukit View, Kaki Bukit Techpark II (S) 415948

Tel: (65) 6844 0660 Fax: (65) 6844 0112 E-mail: sales@rigel.com.sg

Office Working Hours: 8:30am - 6.00pm (Monday to Thursday)

8:30am - 5:30pm (Friday)

Website: www.rigel.com.sg

RIGEL TECHNOLOGY (M) SDN BHD

Wisma Rigel, 16 & 18, Jalan 3 / 33B, MWE Commercial Park, 6 1/2 Miles, Off Jalan Kepong,

52000 Kuala Lumpur, Malaysia

Tel: (603) 6258 6016 Fax: (603) 6258 5498 E-mail: sales@rigel.com.my

Office Working Hours: 8:30am - 6.00pm (Monday to Friday)

Website: www.rigel.com.my

RIGEL TECHNOLOGY (NINGBO) CO. LTD

No 18, Xingye Road 2, Ningbo Beilun Free Trade East Zone, 315800 Ningbo, Zhejiang, China

Tel: (86) 574 5626 1688 Fax: (86) 574 5626 1588 E-mail: sales@rigel.com.sg

RIGEL CERAMICS (SICHUAN) CO. LTD

Shuanghechang, Anfu Town, Naxi District, 646300 Luzhou City, Sichuan, China

Tel: (86) 830 4270 155 Fax: (86) 830 4270 636 E-mail: sales@rigel.com.sg

SAFETY PRECAUTIONS

The precautions noted within this guide are intended to instruct you in the safe and correct use of the products and to prevent injuries and damage to yourself, other persons and property.

IMPORTANT

PLEASE READ THIS MANUAL AND ENSURE THAT YOU UNDERSTAND THEM BEFORE INSTALLING OR OPERATING THE PRODUCTS.

DISCLAIMER

- While every effort has been made to ensure that the information contained in this guide is accurate and complete, no liability can be accepted for any errors or omissions. Rigel reserves the right to change the specifications of the products and function described herein at any time without prior notice.
- No part of this guide may be reproduced, transmitted, transcribed, or translated into any language without prior written permission of Rigel.

IMPORTANT SAFETY INFORMATION

- 1) Products manufactured in Rigel are safe and without risk provided that they are installed, used and maintained in good working order in accordance with our instructions and recommendations.
- 2) There are no user serviceable parts in this product, only a competent tradesperson should dismantle the unit to carry out repairs.
- 3) Any person who may have difficulty understanding or operating the controls of the product should be supervised while using the appliance. Particular consideration should be given to the young, the elderly, the infirm or anyone inexperienced in the correct operation of the controls.

WARRANTY

Rigel Technology (M) Sdn Bhd guarantees products against any defect of materials or workmanship for 1 year from the date of purchase. Within the guarantee period, all defective parts will be repaired and/or replaced free of charge. To be eligible for free repair and/or replacement, any service work on the product in question must only be undertaken by Rigel Technology (M) Sdn Bhd or approved agents. Service under this guarantee does not affect the warranty expiry date. The guarantee on any exchanged parts or products ends when the normal product guarantee period expires.

This warranty applies only to products properly installed and operated within specified environment conditions. This warranty does not extend to washroom accessories or other peripheral items.

Rigel's responsibility under this warranty does not apply to:

1. Misuse, negligence or accidents
2. Public abuse or vandalism
3. Repairs or alteration of products not authorised by / performed without consulting Rigel
4. Repair or alteration works that do not comply with manufacturer's installation instructions or not using genuine spare parts supplied by Rigel

In addition, Rigel will not be liable for any incidental or consequential damages, including loss of profits or savings that arise out of the use or misuse of the products.

The terms of this warranty are only valid after:

1. Full payment has been made
2. The official warranty card has been completely and correctly filled out in ink and returned to Rigel within 14 days of purchase. Loss or misplacement of the card and/or amendments done without authorisation will render the warranty null and void.

This warranty is in addition to your statutory and other legal rights.

INSTALLATION INSTRUCTIONS

(Items shown are illustrations only, and therefore may not reflect actual model supplied)

WALL HUNG BASIN

PLEASE READ THE INSTRUCTIONS CAREFULLY BEFORE DOING ANY INSTALLATION.

1

a) Draw horizontal lines according to the heights stated in the **TEMPLATE** provided.
 b) Position and adjust the **TEMPLATE** to gauge overall correctness.
 c) Mark out and drill pilot holes for **EXPANSION SCREWS**.

2

a) Detailed drawing of the previous diagram.
 b) The **TEMPLATE** is shown here to help envisage the position and alignment.

3

Insert the **EXPANSION SCREWS** into the holes as shown.

4

Align the ware with the mounting screw and slowly press it against the wall. Fasten the ware with the nuts and plastic capping as shown.

5

a) Plastic bush for leveling adjustment rotate hexagonal head.
 b) Apply silicone gel along the periphery of ware that meets with the wall.
 c) Fix wall mount bracket into position and screw tight.

6

Fix the waste plug & bottle trap to position as shown.

PACKING LIST

S/N	PICTURE	DESCRIPTION	QTY
1		WALL HUNG BASIN	1 PC
2		OVERFLOW RING (PA-XFS30001)	1 PC
3		WASTE TRAP (PA-KJ23W)	1 SET
4		PVC BOTTLE TRAP (PA-WP32PVC)	1 SET
5		EXPANDED SCREW & NUT / PLASTIC CAPPING (M10x120mm & 270211 & 1k1391)	1 SET
6		WALL MOUNT BRACKET SET (PA-WM2X3 1/2)	1 SET
7		WARRANTY CARD	1 PC
8		INSTALLATION MANUAL	1 PC
9		TEMPLATE	1 PC

R-LH8080

PRODUCT DIMENSION

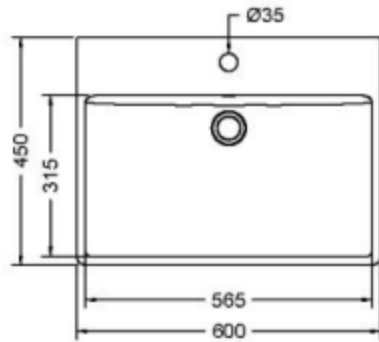

TOP VIEW

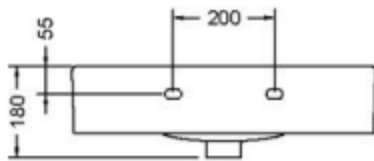

FRONT VIEW

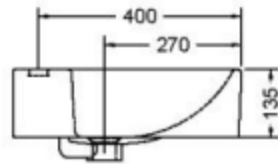

SIDE VIEW

R-LH8080

RECOMMENDED INSTALLATION DETAIL

* Denotes recommended value

